

Lesson Two



A Unique Man & Ministry

"Son of man, I have made thee a watchman unto the house of Israel: therefore hear the word at my mouth, and give them warning from me."

Look around and see the glory of the Lord. walk in obedience following Ezekiel's example in serving the Lord. be a watchman, hear from the Lord and warn people to be prepared for the Lord's appearing and return.

Overview of Lesson Two

I. Setting the Stage

- *A look at genealogies and events*
- *Identifying three Old Testament priests/prophets*

II. Diasporas & Aliyahs

III. Ezekiel's Peculiar Attributes

- *His name*
- *His message*
- *His calling*
- *His handicaps*
- *His diet*

IV. Ezekiel's consistency in obedience

V. The Four Living Creatures

VI. How to See the Glory of the Lord

Follow Along Outline

Not one prophecy is yet to be fulfilled before the rapture of the church.

A look at genealogies and events

- ▶ We see these two uniquely combined in Matthew 1:17 – from Abraham to David 14 generations, from David to the carrying away into Babylon 14 generations, and from the carrying away into Babylon to Christ 14 generations. The _____ was a very unique event.

Three Old Testament priest/prophets

- ▶ _____ was 30 years of age when he was taken into Babylonian captivity in 597 B.C. He had already qualified as a priest, but was never able to practice the priesthood.
- ▶ _____ was a priest who God called to be a prophet.
- ▶ _____ was a priest who God called to be a prophet and who returned to Jerusalem encouraging the people to rebuild the Temple.

Three Diasporas and Aliyahs

- ▶ In Genesis Jacob took his 70 family members into Egypt, dispersed from out of the land due to famine. 430 years later through the leadership of Moses and Joshua they are delivered (commemorated by the Feast of _____) and return two million strong.
- ▶ The dispersion of the Jews to _____ occurred in 605 B.C. with Daniel and the three Hebrew children, then Ezekiel in 597 B.C. and all the Jews in 586 B.C.. God raises up King Cyrus to allow the Jews to return to Jerusalem and build their Temple.
- ▶ The third departure of the people being taken out of the land occurred in 70 A.D. when the _____ was destroyed. The third return is in the process in our life time as described in Daniel 2:7. The Tribulation period is unfolding. God will bring to an end the times of the Gentiles.

The Times in which the Prophets Prophesied

- ▶ During the Babylonian captivity – _____ and _____
- ▶ After the return from the Babylonian captivity – _____, _____ and _____
- ▶ Prior to the Babylonian captivity – the other _____ prophets in the Old Testament

Distinguish between a true prophet and a false prophet

- ▶ The mark of a true prophet is ____% fulfillment of his prophecies.
- ▶ The mark of a false prophet is _____ (Matthew 24:4, 5, 11, 24) made manifest in signs, wonders and miracles.

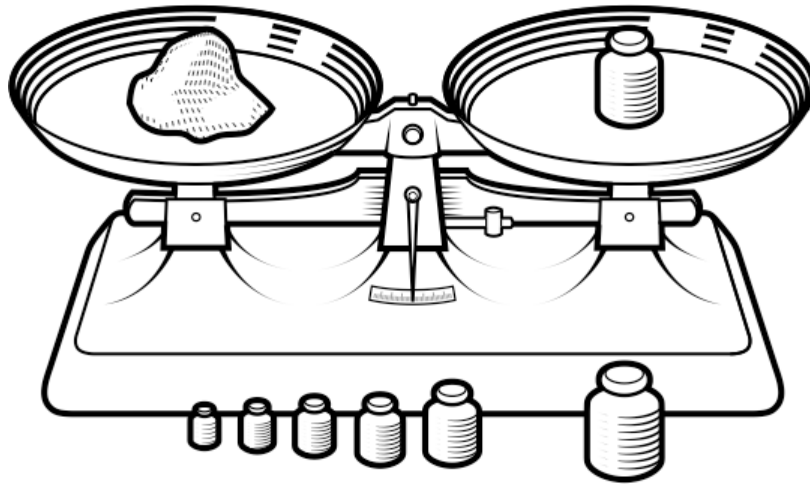

Ezekiel's Peculiar Attributes

- ▶ He is called "son of man" ____ times in this book. There is only one other person with that name, Jesus Christ, used only ____ times in the New Testament.
- ▶ His message was "Thus saith the Lord," used _____ times in the book of Ezekiel.
- ▶ His hearers (Israel) are described as hard headed, stiff necked, impudent, like scorpions, a _____ house.
- ▶ His calling was to be a _____, one who would stand on the city wall giving warning in defense against the enemy. We need to hear and talk what God's Word is saying about the end times in which we are living today warning the people.
- ▶ His handicap was that he was to lay in the street ____ days stricken unable to _____ - a silent street preacher.
- ▶ His daily diet was 8 ounces of meat, a quart of water and bread made over cow _____.

Three piles of hair shaved from Ezekiel's head and face - *Ezekiel 5:1, 2*

- ▶ The pile burned up = a third of Israel will die of pestilence and _____. - *Ezekiel 5:12*
- ▶ The pile stabbed by his dagger = a third of Israel will fall by the _____.
- ▶ The pile scattered by the winds = a third of Israel will be taken into _____.

What was Ezekiel's assignment in the valley of dry bones? - *Ezekiel 37*

- ▶ He was to go out and _____ (preach) to these dry bones.

When God said...

"Go to your people, a rebellious people and speak to them no matter what they say or look like."

Ezekiel said, "Yes sir!"

"Lay in the street 430 days on your left and right sides."

Ezekiel replied, "Yes sir!"

"Bake your bread over cow manure."

Ezekiel answered, "Yes sir!"

"Cut your hair off, stab it, burn it and then throw it in the air."

Ezekiel declared, "Yes sir!"

"I am going to take your beloved wife, but don't mourn. Get back to the task."

Ezekiel responded, "Yes sir!"

"Preach to a valley of dry bones,."

Ezekiel's reaction to God's command was always "Yes sir!"

The Four Living Creatures

- ▶ They are _____. - *Ezekiel 10*
- ▶ They all had four _____ and four _____. - *Ezekiel 1:6*
- ▶ They were standing in the form of a _____ forming a throne _____ to bring the glory of the Lord to the earth.
- ▶ The likeness of their faces were the face of a _____, a _____, an _____ and an _____. - *Ezekiel 1:10*
- ▶ It is believed that these display the different aspects of Jesus Christ as He came to earth.
 - Matthew describes Jesus as _____, King of Kings and Lord of Lords – the face of a lion, the _____ of the animal world.
 - Mark presents Jesus as a _____, the ox, the _____ animal.
 - Luke presents Jesus as a _____, the face of a _____.
 - John presents Jesus as _____, the face of an _____.
- ▶ The cherubim stand with two wings out and two wings covering their bodies, forming a perfect _____ with four _____ in all directions. - *Ezekiel 1:11*
- ▶ A _____ in the middle of a _____, that's how they move.
- ▶ The noise of their _____ was like the noise of many _____, as the voice of the _____.
- ▶ Ezekiel could say, "_____!" because he saw the _____ of the _____, a pre-incarnate appearance of Christ.

How to See the Glory of the Lord

- ▶ If we literally see the _____ of the _____, we will be immediately obedient as well. According to Psalm 19:1-6 we see it in God's _____. *"The heavens declare the _____ of _____; and the firmament sheweth his handiwork."* - Psalm 19:1
- ▶ In Genesis 1 He creates the sun, the moon and the stars also. In the end times there will be those who will deny the _____ of the Lord and His _____. II Peter 3:5 says they will be *"willfully ignorant"* (dumb on purpose).

Conclusion

- ▶ Look around, and see the glory of the Lord.
- ▶ Walk with the Lord today in obedience, and be a blessing.
- ▶ Be a watchman. Hear from the Lord. Warn the people.
- ▶ It is good to know the prophecies of Scripture about the Lord. It is better to love the Lord. Such love causes a sincere longing to see Him face-to-face.
- ▶ A crown of righteousness for all who love His appearing. - *II Timothy 4:7, 8*

Think About This!

1. Who were the three Old Testament prophets who were also priests?
2. What are the three time periods in which the prophets preached?
3. How can you distinguish between a true prophet and a false prophet?
4. How do the four faces of the living creatures relate to the four gospels?
5. What should our reaction be to God when He gives us a command?